



WS Series Electric Pallet Truck With Lithium Battery

with capacities of 1,500/1,800/2,000kg

The World of Hangcha
SINCE 1956



PERFORMANCE

Traveling speed

— UNLADEN 4.5Km/h

+ LADEN 4Km/h

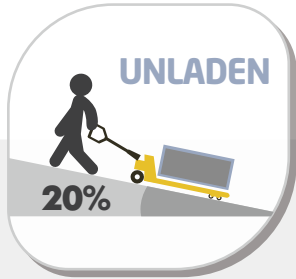

Semi-Electric



BUILT TO WORK
24
HOURS

SMART SIZE
ALMOST SAME

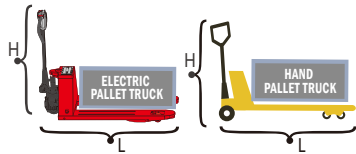

LIGHT WEIGHT

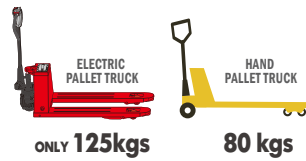

EFFICIENCY

3 Times Higher Than Manual Pallet Truck

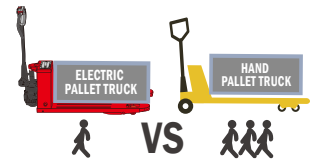

EASY MAINTENANCE

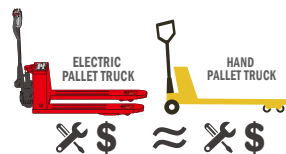

LIFETIME

3 Times Longer Than Manual Pallet Truck

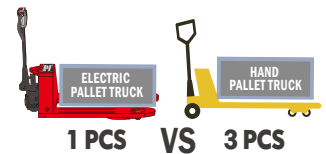

PAY A LITTLE MORE
SAVE MUCH MORE

max

SMART FUNCTION

SMART FUNCTION 01

Turtle Speed

Horn Remains Pressed & Forward 2 times

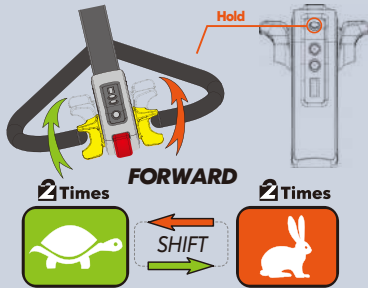

SMART FUNCTION 02

Up-Right Drive

Reverse Button & Forward Throttle Remain Pressed, Power On

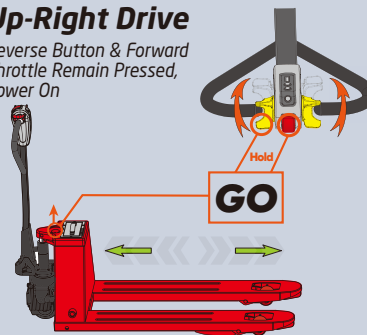

SMART FUNCTION 03

⚠ **Engineering Mode (Brake Release)**
Horn Remains Pressed, Power On

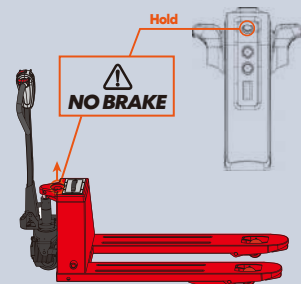

⚠ In up-right drive mode, vehicle will move when handle is operated at any position. Please avoid misoperation.

⚠ Brake release mode is only for emergencies, not allowed for vehicle with normal conditions.

MAINTENANCE SO EASY

5 YEAR WARRANTY CHASSIS



Brushless drive motor, maintenance free



Lithium battery maintenance free



Recharge Alert



Error code display











6s Replace Battery



60s Replace Drive Wheel

CHARACTERISTICS

■ 75mm Lowered height of fork

-  Recharge alert
-  Hour meter
-  Powered traveling
-  Powered lifting & lowering
-  Error code display
-  PIN access control
-  Emergency stop button
-  Horn

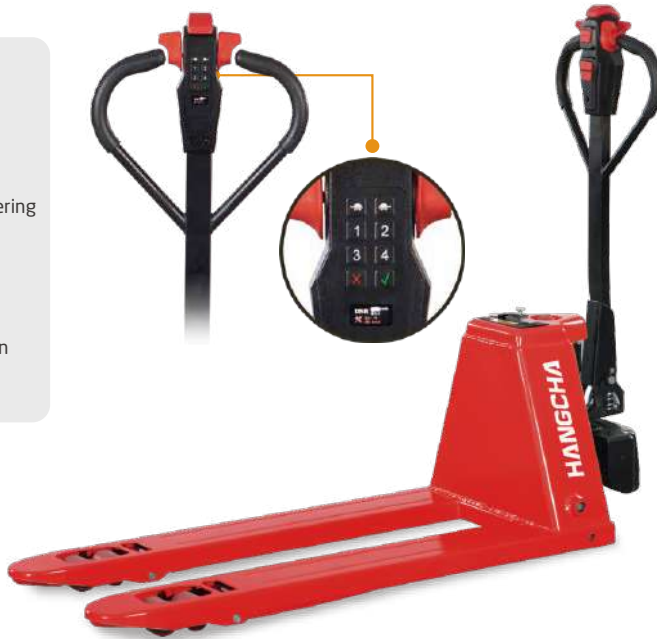

■ 65mm/82mm Lowered height of fork



Multi-function Handle
(Full Electric)

- Emergency reverse button
- Horn
- Forward/reverse butterfly switch
- Lifting / Lowering

LCD Screen

- ◆ Battery indicator with hour meter
- ◆ Error code display
- ◆ Recharge Alert



Multi-function Ergonomic Handle
(Semi-electric)



Protection cover



Electric Lifting/Lowering



Battery Protection Stopper

OPTIONS



Tandem/Single PU wheel



15Ah Lithium Battery



Fast Charger 2hrs



Intelligent Control Key



Low profile forks
Lowered fork height: 65mm
Standard model: 82mm

WS Series Electric Pallet Truck With Lithium Battery Specification

		Manufacturer		HANGCHA GROUP CO.,LTD.					
		Model		CBD18-WS-SE	CBD20-WS-SE	CBD15-WS	CBD15-WS-65L	CBD20-WS	
Characteristics	1.1	Capacity	kg	1800	2000	1500	1500	2000	
	1.2	Load centre distance	mm	600	600	600	600	600	
	1.3	Standard overall fork width	mm	550/685	550/685	520/550/685	550/685	550/685	
	1.4	Fork length	mm	1150/1220	1150/1220	1150/1220	1150/1220	1150/1220	
	1.5	Overall length	mm	1552/1622	1552/1622	1552/1622	1552/1622	1552/1622	
	1.6	Wheelbase	mm	1197/1267	1197/1267	1197/1267	1197/1267	1197/1267	
	1.7	Lowered height of fork	mm	82±2	82±2	82±2	65±2	82±2	
	1.8	MAX height of fork	mm	197	197	197	165	197	
	1.9	Overall length (with tiller)	mm	1300	1300	1250	1250	1250	
	1.10	Rear body width	mm	550/685	550/685	520/550/685	550/685	550/685	
	1.11	Minimum turning radius	mm	1353/1426	1353/1426	1353/1426	1353/1426	1353/1426	
Performance	2.1	Max.Traveling speed	laden	km/h	4	4	4	4	4
			unladen	km/h	4.5	4.5	4.5	4.5	4.5
	2.2	Gradeability	laden	%	6	6	6	6	6
			unladen	%	20	20	20	20	20
	2.3	Traveling	kW	DC 0.75 Brushless	DC 1.0 Brushless	DC 0.75 Brushless	DC 0.75 Brushless	DC 1.0 Brushless	
	2.4	Lifting	kW	Hydraulic	Hydraulic	DC 0.8	DC 0.8	DC 0.8	
2.5	Lifting speed, laden/unladen	mm/s	/	/	18/23	18/23	18/23		
2.6	Lowering speed, laden/unladen	mm/s	/	/	56/46	56/46	56/46		
Battery	4.1	Voltage	V	48	48	48	48	48	
	4.2	Capacity/type	Ah	10Ah Lithium	10Ah Lithium	10Ah Lithium	10Ah Lithium	10Ah Lithium	
Brake type	5.1	Travel brake		Regenerate	Regenerate	Regenerate	Regenerate	Regenerate	
	5.2	Brake		Electromagnetic	Electromagnetic	Electromagnetic	Electromagnetic	Electromagnetic	
Controller	6.1	Controller		B1503	B1503	B1503	B1503	B1503	

- 520mm fork width: only for CBD15-WS model.
- Short fork length: 800mm/900mm/1000mm.
- Long fork length: 1300mm/1500mm(only for CBD15-WS model).
- 65 low profile: only two sizes can be produced :550*1150mm/685*1220mm.
- 75 Low Profile: for CBD15-WS and CBD20-WS, with the combination lock handle.
- Battery: 1.5T with 10ah lithium battery standard, 2.0T with 10ah lithium battery standard.

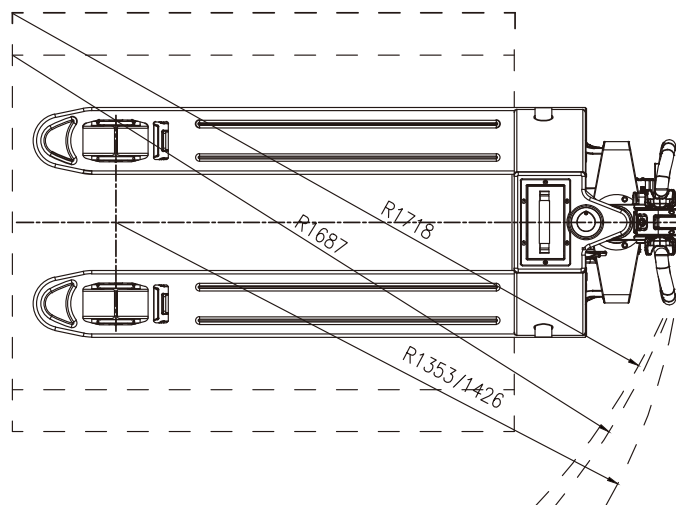
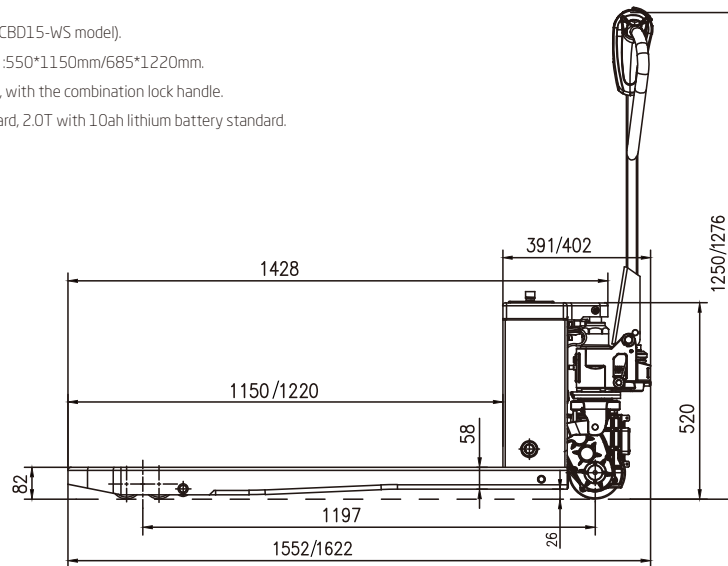



HANGCHA FORKLIFT CANADA INC.

Company address:
100-3801 F.-X.-Tessier,
Vaudreuil-Dorion, QC J7V 5V5

Toll Free: 877-319-HCFC (4232)
Landline: 450-319-HCFC

info@hcforkliftcanada.com
www.hcforkliftcanada.com



ISO14001
ISO14001:2015



ISO9001
ISO9001:2015



Follow us on
Facebook



Follow us on
YouTube



Follow us on
WeChat



Download "Hangcha
Forklift" App

HANGCHA GROUP CO., LTD. reserves the right to make any changes without notice concerning colors, equipment, or specifications detailed in this brochure, or to discontinue individual models. The colors of trucks, delivered may differ slightly from those in brochures.